

ADJUSTABLE
FLOW REGULATORS

anjos

inspirer le bien-être

RDR

Ø 80 to Ø 250 mm

Adjustable flows rates
Self adjusting from 50 to 250 Pa





- Self adjusting on the pressure range 50 to 250 Pa
- Easy adjustment
- The requested air flow is fixed by a screwdriver «torx n°10»
- Made in plastic material (classified M1)
- Use with a maximum temperature of 60°C.

RDR

Presentation

The flow regulator RDR is an element placed inside the duct in order to obtain a constant flow within a pressure range from 50 to 250 Pascals.

It is used in air conditioning or ventilation systems either in extraction or blowing mode.

Aerulic characteristics meeting the requirements of the draft standard NF-E-51-776-2



The self adjusting flow regulator RDR can be adjusted on sites according to the requested airflow.

The marks on the sides of the opening indicate the settings.

Component and dimensions

Flow regulator RDR Ø 80, Ø 100 and Ø 125 ($\leq 100 \text{ m}^3/\text{h}$)

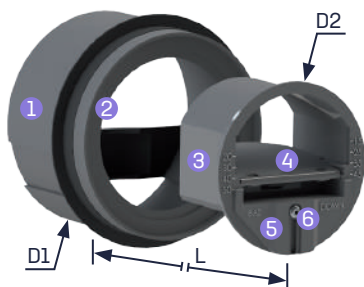

- 1 Sleeve with lip seal
- 2 Spacer (according to the airflow)
- 3 Regulator casing
- 4 Piece of regulation
- 5 Air flow setting
- 6 Screw to fix the airflow

RDR	D1 (mm)	D2 (mm)	L (mm)
Ø 80	76	76	57
Ø 100	96	93	68
Ø 125	120	60	68

Flow regulator RDR Ø 125 to Ø 250

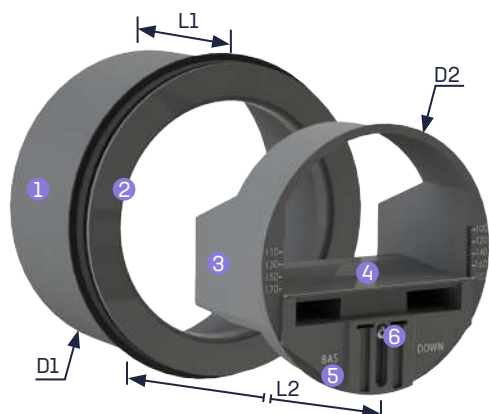

- 1 Sleeve with lip seal
- 2 Spacer (according to the airflow)
- 3 Regulator casing
- 4 Piece of regulation
- 5 Air flow setting
- 6 Screw to fix the airflow

RDR	D1 (mm)	D2 (mm)	L1 (mm)	L2 (mm)
Ø 125	120	117	80	86
Ø 150	148	148	78	85
Ø 160	148	148	78	85
Ø 200	195	195	82	91
Ø 250	244	245	82	120

RDR composition table according to flows

RDR	Setting	Flow (m³/h)	Set flow (m³/h)	Code
Ø 80	RDR Ø 80	15 to 50	50	9404
Ø 100	RDR Ø 80 + 1 spacer	15 to 50	50	9409
Ø 100	RDR Ø 100	50 to 100	100	9413
Ø 125	RDR Ø 80 + 1 spacer ²	15 to 50	50	9419
Ø 125	RDR Ø 100 + 1 spacer	50 to 100	100	9423
Ø 125	RDR Ø 125	100 to 180	180	9427
Ø 150	RDR Ø 80 + 2 spacers ²	15 to 50	50	9430
Ø 150	RDR Ø 100 + 2 spacers	50 to 100	100	9431
Ø 150	RDR Ø 125 + 1 spacer	100 to 180	180	9434
Ø 150	RDR Ø 150	180 to 300	300	9439
Ø 160	RDR Ø 80 + 2 spacers ²	15 to 50	50	9440
Ø 160	RDR Ø 100 + 2 spacers	50 to 100	100	9441

² :made with a double spacer

Possibility to get Fire Resistant components

RDR	Setting	Flow (m³/h)	Set flow (m³/h)	Code
Ø 160	RDR Ø 125 + 1 spacer	100 to 180	180	9444
Ø 160	RDR Ø 150	180 to 300	300	9449
Ø 200	RDR Ø 80 + 3 spacers ²	15 to 50	50	9455
Ø 200	RDR Ø 100 + 3 spacers	50 to 100	100	9456
Ø 200	RDR Ø 125 + 2 spacers	100 to 180	180	9457
Ø 200	RDR Ø 160 + 1 spacer	180 to 300	300	9464
Ø 200	RDR Ø 200	300 to 500	500	9468
Ø 250	RDR Ø 100 + 4 spacers	50 to 100	100	9475
Ø 250	RDR Ø 125 + 3 spacers	100 to 180	180	9476
Ø 250	RDR Ø 160 + 2 spacers	180 to 300	300	9477
Ø 250	RDR Ø 200 + 1 spacer	300 to 500	500	9483
Ø 250	RDR Ø 250	450 to 800	800	9490

Principle of operation

In the example below with the RDR placed in a metal duct, the regulator element of the RDR (in yellow) decreases the air passage section with the increase of the pressure difference between the

upstream and the downstream of the regulator, thus regulating the flow over the pressure range between 50 and 250 Pa.

RDR Ø 80 and Ø 100 in the duct



Low pressure difference

Sense of air



High pressure difference

RDR Ø 125 à Ø 250 in the duct

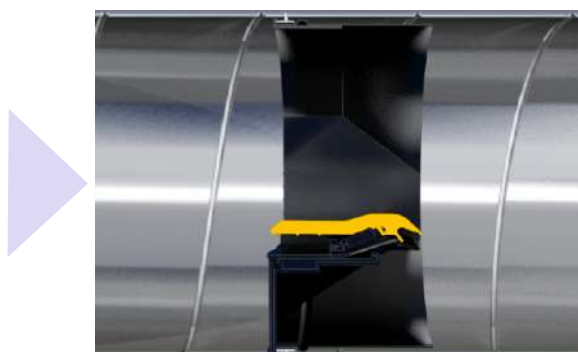

Low pressure difference

Sens of air



High pressure difference

Adjustment

Before setting the regulator, it's necessary to calibrate the flow :

- Using a T10 Torx screwdriver, loosen the screw on the adjustment module by one-quarter turn.
- Set the cursor (on the left or right) to the desired flow rate.
- Retighten the adjustment module locking screw.



RDR Ø 80 and 100 mm



Example of an adjustment at 50 m³/h:
regulator set at the «50» mark on the left

It is possible to obtain other flow rates than those indicated on the controller by setting the mark of the adjustment module to an intermediary position. The setting steps are given in the table opposite.

RDR Ø 125 to 250 mm



Example of an adjustment at 180 m³/h:
regulator set at the «180» mark on the right

Flow regulator	Intermediary step
RDR Ø 80	2,5 m ³ /h
RDR Ø 100 - 125 - 150 - 160	5 m ³ /h
RDR Ø 200	10 m ³ /h
RDR Ø 250	25 m ³ /h

Installation

The flow regulators are simply fitted into vertical or horizontal ducts. In the horizontal duct, respect the mention «DOWN» indicated at the front of the product. A lip seal ensures the airtightness.

When the flow regulator is associated with a diffuser, the minimum distance between the diffuser and the regulator is at least one diameter in extraction mode and 3 diameters in blowing mode.

! When installing, do not touch the piece of regulation

It is essential to comply with the direction of air flow shown on the sleeve.

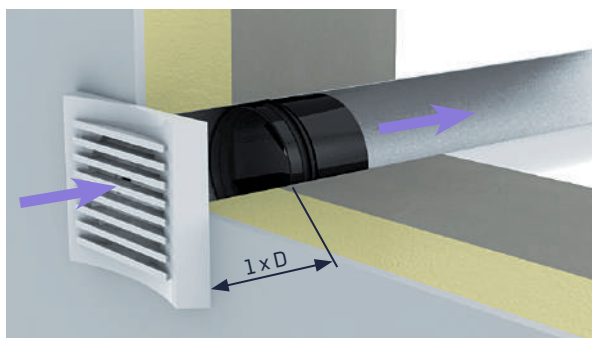

Flow regulator in extraction mode

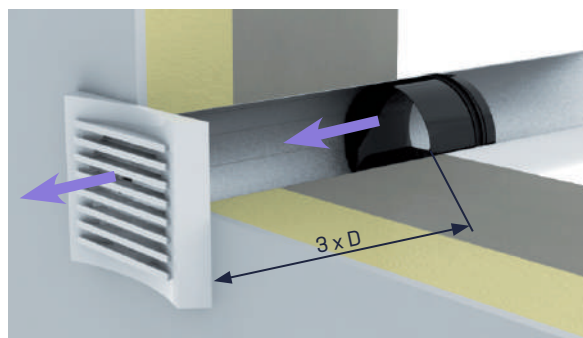

Flow regulator in blowing mode

Maintenance

The flow regulator must remain accessible to permit its maintenance.

Aeraulic Characteristics

Ø 80 - 100 mm

The curves show the flow variations in m³/h of RDR Ø 80 and 100 mm in extraction according to the difference of pressure in Pascal (pressure range of 50 to 250 Pa).

The aeraulic characteristics meet the requirements of the standard NF-E 51-776-2 (test reports n° 1660221-3).

Flow regulator Ø 80 - 15 to 50 m³/h

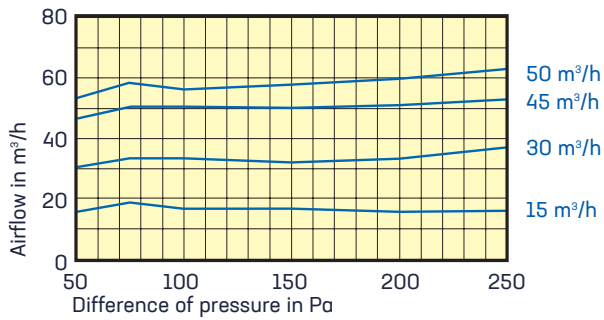

Flow regulator Ø 100 - 15 to 50 m³/h

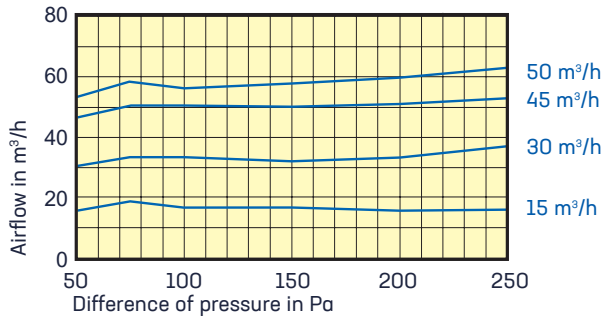

Flow regulator Ø 100 - 50 to 100 m³/h

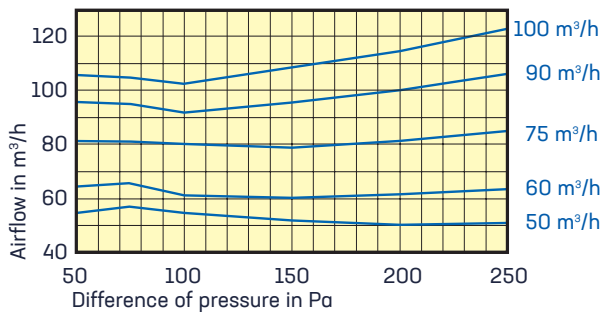

Aeraulic Characteristics

Ø 125 - 150 - 160 mm

The curves show the flow variations in m³/h of RDR Ø 125, 150 and 160 mm in extraction according to the difference of pressure in Pascal (pressure range of 50 to 250 Pa).

The aeraulic characteristics meet the requirements of the standard NF-E 51-776-2 (test reports n° 1660221-3).

Flow regulator Ø 125 - 15 to 50 m³/h

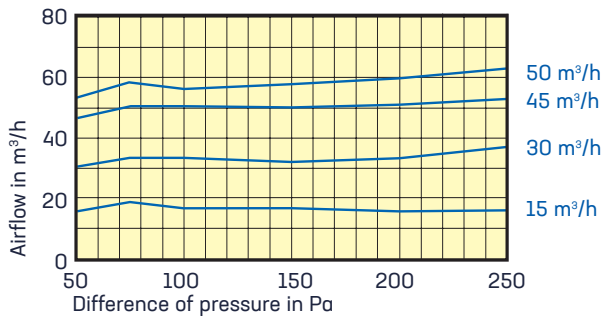

Flow regulator Ø 125 - 50 to 100 m³/h

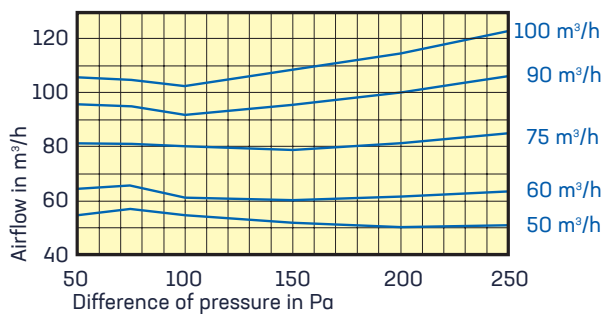

Flow regulator Ø 125 - 100 to 180 m³/h

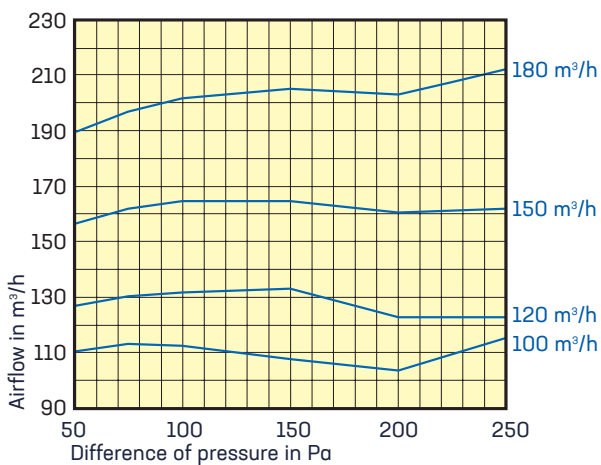

Flow regulator Ø 150/160 - 50 to 100 m³/h

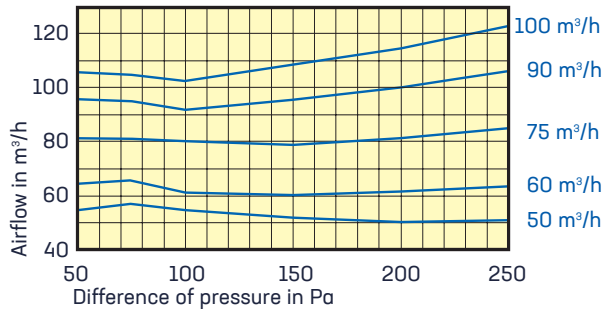

Flow regulator Ø 150/160 - 100 to 180 m³/h

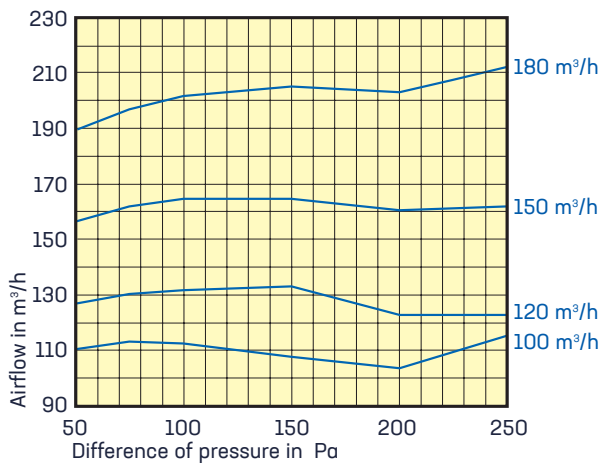

Flow regulator Ø 150/160 - 180 to 300 m³/h

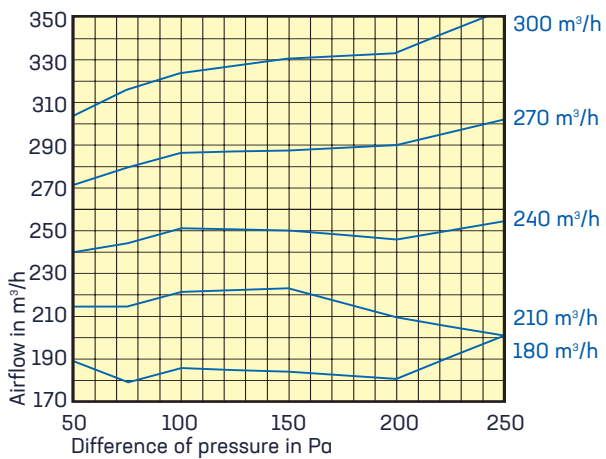

Aeraulic Characteristics

Ø 200 - 250 mm

The curves show the flow variations in m³/h of RDR Ø 200 and 250 mm in extraction according to the difference of pressure in Pascal (pressure range of 50 to 250 Pa).

The aeraulic characteristics meet the requirements of the standard NF-E 51-776-2 (test reports n° 1660221-4).

Flow regulator Ø 200 - 100 to 180 m³/h

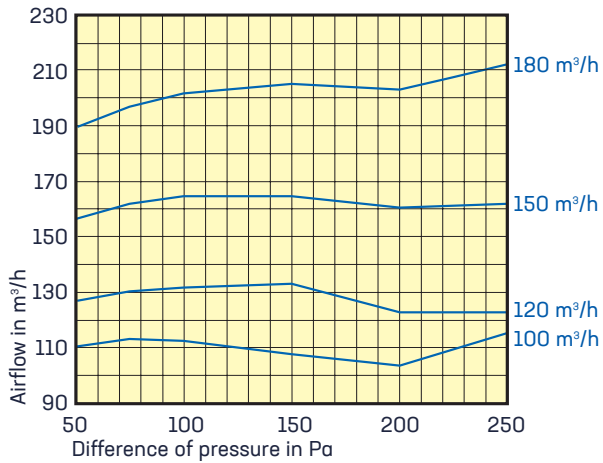

Flow regulator Ø 200 - 180 to 300 m³/h

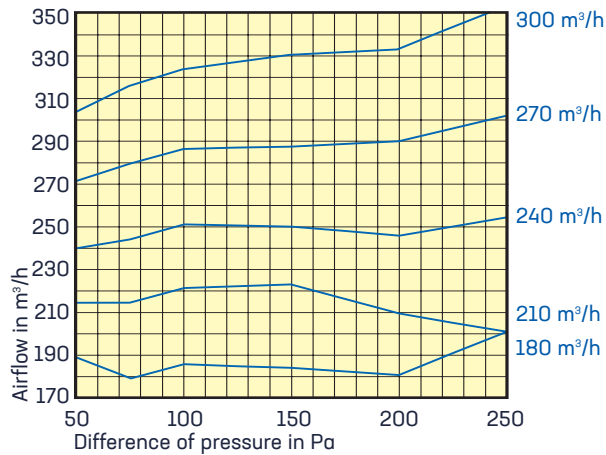

Flow regulator Ø 200 - 300 to 500 m³/h

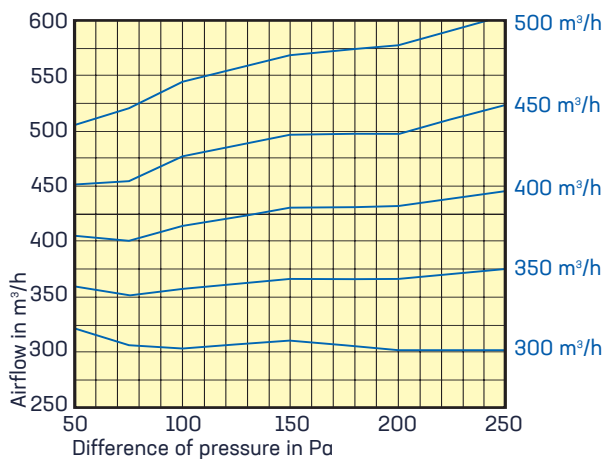

Flow regulator Ø 250 - 180 to 300 m³/h

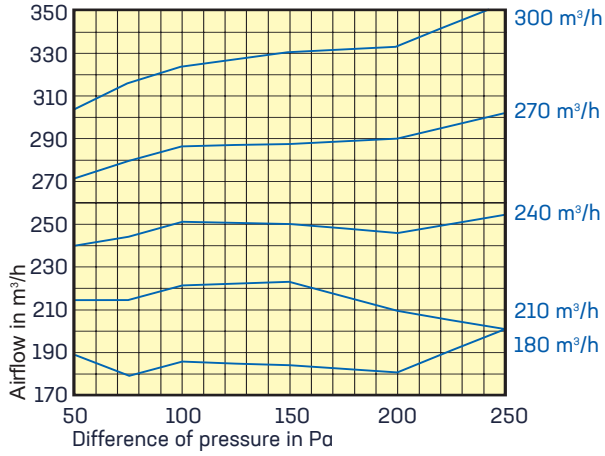

Flow regulator Ø 250 - 300 to 500 m³/h

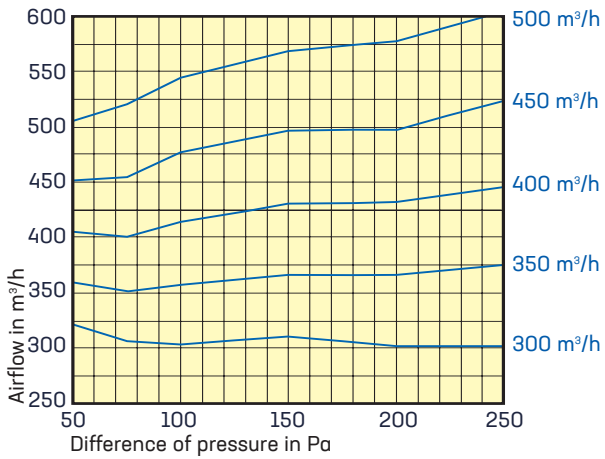

Flow regulator Ø 250 - 450 to 800 m³/h

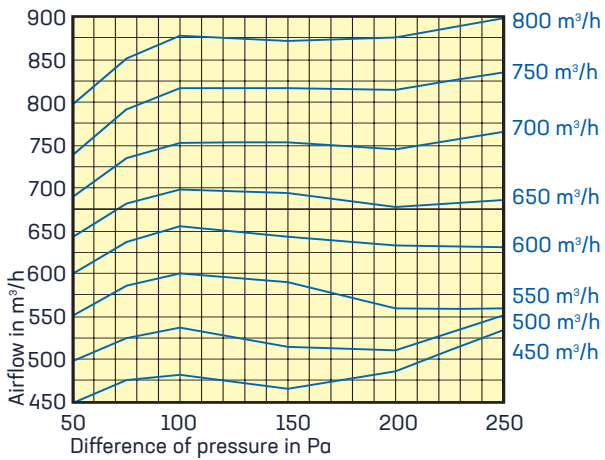

Acoustic Characteristics

Ø 80 - 100 mm

The following tables give, for each RDR, the sound power levels per octave in dB and the sound power levels L_w in dB (A) as a function of the pressure difference, measured at the output of the duct.

The tests are carried out according to standard NF EN ISO 3741 and NF EN ISO 5135.

Flow regulator Ø 80

Ø 80	Flow	Set flow	Difference of pressure	125 Hz	250 Hz	500 Hz	1000 Hz	2000 Hz	4000 Hz	8000 Hz	L_w (dB(A))
Ø 80 RDR 80	15 to 50 m³/h	15 m³/h	50 Pa	24	18	15	15	16	16	20	24
			100 Pa	25	22	21	25	25	21	20	30
			150 Pa	25	21	22	28	28	26	21	33
			200 Pa	25	23	24	30	30	27	23	35
			250 Pa	26	24	25	31	32	27	24	37
		25 m³/h	50 Pa	25	24	20	20	19	16	20	26
			100 Pa	25	25	26	30	26	21	20	33
			150 Pa	26	27	30	35	32	24	21	38
			200 Pa	27	28	33	38	38	28	23	42
			250 Pa	27	29	34	40	41	33	26	45
		30 m³/h	50 Pa	27	24	21	21	18	17	20	27
			100 Pa	27	26	27	30	26	20	20	33
			150 Pa	29	29	31	36	32	23	21	39
			200 Pa	30	31	35	40	37	27	23	43
			250 Pa	31	32	37	42	39	31	25	45
		45 m³/h	50 Pa	30	25	21	22	17	16	20	27
			100 Pa	32	28	26	29	27	19	20	33
			150 Pa	33	31	30	35	34	24	21	39
			200 Pa	35	33	33	37	38	27	23	42
			250 Pa	35	35	36	41	41	31	26	45
		50 m³/h	50 Pa	31	27	22	23	18	16	20	28
			100 Pa	32	29	27	30	28	19	20	34
			150 Pa	35	32	31	34	34	24	21	38
			200 Pa	36	35	34	37	38	27	23	42
250 Pa	37		37	37	40	40	31	26	45		

Flow regulator Ø 100

Ø 100	Flow	Set flow	Difference of pressure	125 Hz	250 Hz	500 Hz	1000 Hz	2000 Hz	4000 Hz	8000 Hz	L _w (dB(A))		
Ø 100 RDR 80 + 1 spacer	15 to 50 m³/h	15 m³/h	50 Pa	26	19	19	14	14	16	20	24		
			100 Pa	26	21	22	19	20	18	20	26		
			150 Pa	26	24	25	24	25	19	21	30		
			200 Pa	28	26	28	27	29	22	22	33		
			250 Pa	28	28	30	29	32	25	24	36		
		25 m³/h	50 Pa	27	23	25	18	17	16	20	26		
			100 Pa	27	26	32	28	25	21	20	33		
			150 Pa	28	28	36	32	30	24	21	37		
			200 Pa	28	30	39	36	35	27	24	41		
		30 m³/h	250 Pa	29	31	40	39	39		27	44		
			50 Pa	27	24	26	19	17	18	20	27		
			100 Pa	27	26	32	28	24	20	20	33		
			150 Pa	28	29	36	32	30	23	21	37		
		45 m³/h	200 Pa	30	32	40	37	35	27	24	42		
			250 Pa	31	34	43	40	39	32	27	45		
			50 Pa	29	27	28	22	17	16	20	29		
			100 Pa	32	33	36	30	27	19	20	36		
		50 m³/h	150 Pa	36	36	38	34	32	24	21	40		
			200 Pa	37	38	41	36	36	28	23	42		
			250 Pa	39	40	42	38	38	31	26	44		
			50 Pa	30	28	29	22	17	16	20	29		
			100 Pa	33	34	36	31	27	19	20	36		
			150 Pa	35	36	38	33	31	24	21	38		
			200 Pa	37	38	41	36	35	27	23	42		
			250 Pa	38	40	43	38	38	31	26	44		
		Ø 100 RDR 100	50 to 100 m³/h	50 m³/h	50 Pa	32	29	29	21	19	16	20	29
					100 Pa	31	33	35	29	27	19	20	35
					150 Pa	32	35	38	34	33	24	21	40
200 Pa	33				37	41	38	37	28	24	43		
250 Pa	34				39	43	40	40	31	26	45		
60 m³/h	50 Pa			34	30	32	24	22	17	20	31		
	100 Pa			32	35	37	30	29	20	21	37		
	150 Pa			34	37	40	35	35	26	22	41		
	200 Pa			35	39	43	38	38	30	26	44		
75 m³/h	250 Pa			36	41	44	40	40	33	28	46		
	50 Pa			34	31	31	23	20	17	20	31		
	100 Pa			33	37	37	31	30	21	21	38		
	150 Pa			35	39	41	35	36	26	23	42		
90 m³/h	200 Pa			37	42	44	38	39	31	27	45		
	250 Pa			38	44	47	40	41	33	30	48		
	50 Pa			36	33	33	25	22	18	20	33		
	100 Pa			34	37	39	32	32	22	21	39		
100 m³/h	150 Pa			36	40	43	36	37	27	24	43		
	200 Pa			38	42	45	39	39	31	27	46		
	250 Pa			39	44	48	41	41	34	30	48		
	50 Pa			35	33	33	25	22	18	20	33		
	100 Pa			35	36	40	32	31	23	21	39		
	150 Pa			37	39	42	36	37	28	24	43		
	200 Pa			38	41	45	39	40	32	28	46		
	250 Pa			41	43	47	41	42	35	32	48		

Acoustic Characteristics

Ø 125 mm

The following tables give, for each RDR, the sound power levels per octave in dB and the sound power levels L_w in dB (A) as a function of the pressure difference, measured at the output of the duct.

The tests are carried out according to standard NF EN ISO 3741 and NF EN ISO 5135.

Flow regulator Ø 125

Ø 125	Flow	Set flow	Difference of pressure	125 Hz	250 Hz	500 Hz	1000 Hz	2000 Hz	4000 Hz	8000 Hz	L_w (dB(A))
Ø 125 RDR 80 + 1 double spacer	15 to 50 m³/h	15 m³/h	50 Pa	28	21	18	16	17	16	20	25
			100 Pa	28	22	21	23	25	18	20	29
			150 Pa	28	22	22	25	28	26	21	32
			200 Pa	28	23	24	28	29	27	25	34
			250 Pa	28	24	26	30	32	26	26	36
		25 m³/h	50 Pa	27	26	21	19	17	16	20	26
			100 Pa	27	28	27	28	24	20	20	32
			150 Pa	30	31	32	34	30	23	21	37
			200 Pa	31	33	35	38	37	29	24	42
			250 Pa	33	34	36	40	40	34	29	45
		30 m³/h	50 Pa	28	28	22	20	18	17	20	27
			100 Pa	28	29	27	28	24	19	20	32
			150 Pa	30	32	33	34	30	22	21	37
			200 Pa	33	35	37	39	36	26	24	42
			250 Pa	35	37	40	42	40	31	27	46
		45 m³/h	50 Pa	31	31	25	22	17	16	20	28
			100 Pa	29	30	29	29	26	18	20	33
			150 Pa	30	31	31	34	31	22	21	37
			200 Pa	33	34	34	37	36	26	24	41
			250 Pa	36	37	37	39	39	29	26	44
		50 m³/h	50 Pa	33	32	27	24	18	16	20	30
			100 Pa	32	31	30	30	26	18	20	34
			150 Pa	33	33	31	33	31	22	21	37
			200 Pa	37	36	35	36	36	27	24	41
			250 Pa	39	39	37	39	39	30	27	44

Flow regulator Ø 125

Ø 125	Flow	Set flow	Difference of pressure	125 Hz	250 Hz	500 Hz	1000 Hz	2000 Hz	4000 Hz	8000 Hz	L _w (dB(A))		
Ø 125 RDR 100 + 1 spacer	50 to 100 m³/h	50 m³/h	50 Pa	30	27	24	21	18	16	20	27		
			100 Pa	31	30	30	30	27	18	20	34		
			150 Pa	30	32	33	35	33	22	22	39		
			200 Pa	32	34	36	39	38	27	25	43		
			250 Pa	32	36	37	41	41	31	28	45		
		60 m³/h	50 Pa	35	33	26	23	20	16	20	30		
			100 Pa	28	30	31	31	28	19	20	35		
			150 Pa	31	33	34	36	34	23	22	39		
			200 Pa	34	36	36	39	38	28	25	43		
			250 Pa	34	38	38	41	41	31	29	45		
		75 m³/h	50 Pa	37	35	28	24	19	16	20	31		
			100 Pa	30	31	31	31	28	19	21	35		
			150 Pa	32	33	33	35	34	24	22	39		
			200 Pa	34	36	36	38	38	28	26	43		
			250 Pa	35	38	38	40	40	31	29	45		
		90 m³/h	50 Pa	39	36	29	26	20	17	20	32		
			100 Pa	32	31	31	31	29	20	21	35		
			150 Pa	32	33	33	35	34	24	22	39		
			200 Pa	35	36	36	38	38	28	26	43		
			250 Pa	36	38	38	40	40	31	29	45		
		100 m³/h	50 Pa	41	39	31	27	22	17	20	34		
			100 Pa	32	33	32	32	30	20	21	36		
			150 Pa	33	34	34	36	35	25	23	40		
			200 Pa	35	37	37	38	38	29	27	43		
			250 Pa	37	39	39	41	40	32	31	45		
		Ø 125 RDR 125	100 to 180 m³/h	100 m³/h	50 Pa	48	36	31	28	25	18	20	35
					100 Pa	49	40	37	35	32	25	23	40
					150 Pa	52	44	40	39	37	31	28	44
200 Pa	56				48	43	43	40	35	34	48		
250 Pa	58				50	45	46	42	38	37	50		
120 m³/h	50 Pa			44	37	31	29	25	18	20	35		
	100 Pa			49	41	37	36	33	25	23	41		
	150 Pa			51	44	41	39	37	32	29	45		
	200 Pa			50	43	42	42	39	35	34	47		
	250 Pa			49	44	43	44	41	37	36	48		
150 m³/h	50 Pa			48	35	30	30	27	20	21	36		
	100 Pa			51	39	36	37	35	28	24	42		
	150 Pa			52	41	39	40	38	33	30	45		
	200 Pa			53	43	42	43	41	37	35	47		
	250 Pa			53	44	44	45	43	39	38	49		
180 m³/h	50 Pa			51	38	33	32	29	21	21	38		
	100 Pa			52	40	35	36	34	30	24	42		
	150 Pa			52	42	38	39	39	34	31	45		
	200 Pa			53	44	41	42	40	37	36	47		
	250 Pa			54	45	43	44	42	39	38	49		

Acoustic Characteristics

Ø 150 - 160 - 200 mm

The following tables give, for each RDR, the sound power levels per octave in dB and the sound power levels L_w in dB (A) as a function of the pressure difference, measured at the output of the duct.

The tests are carried out according to standard NF EN ISO 3741 and NF EN ISO 5135.

Flow regulator Ø 150 and Ø 160

Ø 150 Ø 160	Flow	Set flow	Difference of pressure	125 Hz	250 Hz	500 Hz	1000 Hz	2000 Hz	4000 Hz	8000 Hz	L_w (dB(A))
Ø 150 - 160 RDR125 + 1 spacer	100 to 180 m³/h	100 m³/h	50 Pa	41	42	37	29	25	18	20	38
			100 Pa	47	45	44	37	33	26	23	44
			150 Pa	49	46	45	40	37	32	28	46
			200 Pa	50	47	46	44	41	37	33	49
			250 Pa	52	49	48	46	44	39	38	51
		120 m³/h	50 Pa	44	43	38	30	26	18	20	39
			100 Pa	47	44	43	38	35	26	24	44
			150 Pa	50	46	46	41	38	33	29	47
			200 Pa	49	46	47	44	41	37	35	49
			250 Pa	48	47	47	45	43	40	37	50
		150 m³/h	50 Pa	46	46	39	31	27	20	21	40
			100 Pa	49	46	45	39	36	29	25	45
			150 Pa	51	47	47	43	41	35	30	49
			200 Pa	51	48	48	46	43	39	36	51
			250 Pa	50	48	49	47	45	41	39	52
		180 m³/h	50 Pa	47	48	40	31	29	21	21	42
			100 Pa	52	47	46	40	37	30	26	47
			150 Pa	53	48	46	43	41	35	31	49
			200 Pa	52	50	48	45	43	39	36	51
			250 Pa	52	51	50	47	45	41	38	53
Ø 150 - 160 RDR150 - 160	180 to 300 m³/h	180 m³/h	50 Pa	47	42	35	31	28	23	21	38
			100 Pa	52	44	39	37	34	30	25	43
			150 Pa	53	46	43	41	38	35	31	46
			200 Pa	56	48	45	44	41	38	35	49
			250 Pa	58	51	48	46	43	41	39	51
		210 m³/h	50 Pa	48	41	37	33	31	25	22	39
			100 Pa	52	45	42	39	37	32	28	45
			150 Pa	53	47	45	42	40	37	33	48
			200 Pa	54	48	48	45	42	40	37	50
			250 Pa	54	47	48	47	44	41	40	52
		240 m³/h	50 Pa	48	41	37	34	31	25	23	40
			100 Pa	52	44	40	39	36	31	27	44
			150 Pa	53	46	43	42	39	36	33	47
			200 Pa	54	47	44	44	40	38	36	49
			250 Pa	54	48	46	46	42	40	38	50
		270 m³/h	50 Pa	47	40	36	33	31	24	22	39
			100 Pa	52	45	41	40	37	32	28	45
			150 Pa	54	47	44	43	40	37	35	48
			200 Pa	54	48	46	45	41	40	38	50
			250 Pa	55	50	48	47	43	42	41	52
300 m³/h	50 Pa	50	42	38	35	34	26	24	41		
	100 Pa	53	45	43	41	39	34	30	46		
	150 Pa	52	47	46	45	42	38	35	49		
	200 Pa	52	50	47	47	43	40	39	51		
	250 Pa	55	51	50	49	46	43	42	53		

Flow regulator Ø 200

Ø 200	Flow	Set flow	Difference of pressure	125 Hz	250 Hz	500 Hz	1000 Hz	2000 Hz	4000 Hz	8000 Hz	L _w (dB(A))
Ø 200 RDR 160 + 1 spacer	180 to 300 m³/h	180 m³/h	50 Pa	47	43	37	29	26	18	20	39
			100 Pa	47	44	44	39	36	29	26	45
			150 Pa	49	45	44	42	40	33	30	47
			200 Pa	52	47	47	45	42	37	35	50
			250 Pa	55	49	49	48	45	40	39	53
		210 m³/h	50 Pa	49	44	37	30	28	20	21	40
			100 Pa	47	45	45	39	37	30	27	46
			150 Pa	48	45	45	42	40	35	31	48
			200 Pa	49	45	46	44	42	38	35	49
			250 Pa	50	46	46	45	44	40	39	51
		240 m³/h	50 Pa	50	45	37	29	28	19	21	40
			100 Pa	47	46	46	40	38	31	28	46
			150 Pa	48	47	47	44	41	35	32	49
			200 Pa	48	47	47	46	44	39	36	51
			250 Pa	49	47	48	48	46	42	41	53
		270 m³/h	50 Pa	50	44	36	30	30	20	21	40
			100 Pa	50	50	47	40	38	30	27	47
			150 Pa	49	49	49	43	41	35	32	50
			200 Pa	48	48	49	46	43	39	36	51
			250 Pa	49	48	49	48	45	42	40	53
300 m³/h	50 Pa	51	46	38	31	33	24	22	42		
	100 Pa	50	51	50	42	40	32	29	50		
	150 Pa	49	50	51	45	43	37	34	52		
	200 Pa	50	50	51	47	44	40	38	53		
	250 Pa	51	50	50	49	46	42	41	54		
Ø 200 RDR 200	300 to 500 m³/h	300 m³/h	50 Pa	45	41	37	33	31	24	22	39
			100 Pa	45	42	41	39	38	31	27	44
			150 Pa	48	46	44	43	41	37	33	48
			200 Pa	48	47	46	45	43	40	37	50
			250 Pa	48	47	48	48	45	42	40	52
		350 m³/h	50 Pa	45	41	39	35	32	25	22	41
			100 Pa	46	43	42	40	38	32	28	45
			150 Pa	48	46	45	44	42	38	34	49
			200 Pa	49	48	47	47	44	41	37	51
			250 Pa	50	49	49	49	46	43	41	54
		400 m³/h	50 Pa	46	42	39	35	31	24	22	41
			100 Pa	46	44	44	42	39	33	28	47
			150 Pa	48	46	47	45	43	39	34	50
			200 Pa	49	48	48	48	45	42	38	52
			250 Pa	50	49	49	50	47	44	41	54
		450 m³/h	50 Pa	46	43	40	35	31	25	22	41
			100 Pa	48	46	45	42	39	34	29	47
			150 Pa	50	48	48	46	43	39	35	51
			200 Pa	50	49	50	48	45	42	39	53
			250 Pa	51	50	51	50	47	45	43	55
500 m³/h	50 Pa	45	43	41	36	33	26	23	42		
	100 Pa	49	46	46	43	40	35	30	48		
	150 Pa	51	49	49	47	44	41	37	52		
	200 Pa	51	50	50	49	46	43	40	54		
	250 Pa	52	51	52	50	48	46	44	56		

Acoustic Characteristics

Ø 250 mm

The following tables give, for each RDR, the sound power levels per octave in dB and the sound power levels L_w in dB (A) as a function of the pressure difference, measured at the output of the duct.

The tests are carried out according to standard NF EN ISO 3741 and NF EN ISO 5135.

Flow regulator Ø 250

Ø 250	Set flow	Flow	Difference of pressure	125 Hz	250 Hz	500 Hz	1000 Hz	2000 Hz	4000 Hz	8000 Hz	L_w (dB(A))
Ø 250 RDR 200 + 1 spacer	300 to 500 m³/h	300 m³/h	50 Pa	45	37	30	26	25	18	20	34
			100 Pa	49	47	42	37	36	30	25	44
			150 Pa	48	48	45	42	40	36	30	48
			200 Pa	47	47	46	44	42	39	34	49
			250 Pa	46	47	47	46	43	41	38	51
		350 m³/h	50 Pa	46	40	33	27	25	18	20	36
			100 Pa	49	48	43	38	34	29	24	45
			150 Pa	48	49	48	43	39	35	30	49
			200 Pa	48	49	48	45	41	38	34	50
			250 Pa	48	49	49	47	43	41	38	52
		400 m³/h	50 Pa	47	40	33	28	26	20	21	37
			100 Pa	51	50	45	39	34	30	25	46
			150 Pa	50	51	50	44	38	36	30	50
			200 Pa	49	51	51	47	41	39	35	52
			250 Pa	49	51	51	49	43	41	39	53
		450 m³/h	50 Pa	47	40	35	29	27	20	21	37
			100 Pa	52	51	46	41	34	30	26	47
			150 Pa	51	53	51	45	39	36	32	52
			200 Pa	51	54	53	48	41	40	36	54
			250 Pa	51	53	54	50	43	43	39	55
		500 m³/h	50 Pa	47	41	35	30	27	20	20	38
			100 Pa	53	51	47	42	35	31	26	48
			150 Pa	53	55	51	46	39	37	34	52
			200 Pa	53	54	54	49	42	40	39	54
			250 Pa	53	55	56	52	45	43	42	56

Flow regulator Ø 250

Ø 250	Set flow	Flow	Difference of pressure	125 Hz	250 Hz	500 Hz	1000 Hz	2000 Hz	4000 Hz	8000 Hz	L _w (dB(A))
Ø 250 RDR 250	450 to 800 m³/h	450 m³/h	50 Pa	38	35	33	31	26	21	21	35
			100 Pa	41	40	39	38	34	34	25	42
			150 Pa	42	42	42	42	38	39	32	47
			200 Pa	44	43	45	45	41	44	37	50
			250 Pa	47	45	47	47	44	46	41	53
		500 m³/h	50 Pa	37	35	34	32	27	22	21	36
			100 Pa	42	40	40	39	36	35	26	44
			150 Pa	42	42	43	43	40	41	33	48
			200 Pa	44	43	46	46	43	45	39	51
			250 Pa	48	49	51	51	49	49	44	56
		550 m³/h	50 Pa	36	44	42	38	35	31	27	44
			100 Pa	44	47	46	43	40	38	30	48
			150 Pa	55	48	47	46	42	43	38	51
			200 Pa	56	49	49	48	45	46	41	54
			250 Pa	50	54	55	53	53	51	45	60
		600 m³/h	50 Pa	39	46	44	40	36	32	29	45
			100 Pa	48	49	48	44	41	39	33	50
			150 Pa	57	50	49	46	43	43	40	52
			200 Pa	53	55	55	53	51	49	45	58
			250 Pa	50	53	56	52	50	50	46	58
		650 m³/h	50 Pa	40	46	44	39	36	33	30	45
			100 Pa	49	50	48	45	41	39	33	50
			150 Pa	57	51	50	48	44	44	41	53
			200 Pa	52	54	54	52	49	49	44	57
			250 Pa	49	53	54	52	49	50	45	58
		700 m³/h	50 Pa	41	46	44	39	36	33	30	46
			100 Pa	49	50	48	46	42	40	33	51
			150 Pa	58	51	52	49	46	45	41	55
			200 Pa	52	54	53	51	48	48	43	56
			250 Pa	49	53	52	52	49	50	45	57
		750 m³/h	50 Pa	42	46	44	40	36	33	29	46
			100 Pa	49	51	49	47	43	41	34	52
			150 Pa	49	53	51	49	45	46	41	55
			200 Pa	50	52	52	51	47	49	44	56
			250 Pa	51	52	54	53	50	51	46	58
		800 m³/h	50 Pa	43	46	45	40	37	34	30	46
			100 Pa	50	53	52	48	44	42	34	54
			150 Pa	52	54	52	50	46	46	42	55
			200 Pa	52	56	53	52	48	49	44	57
			250 Pa	53	57	54	53	50	51	46	59

Codification

	Flow	Description	Code
Ø 80 RDR 80	15 to 50 m³/h	RDR 15 m³/h Ø 80	9400
		RDR 25 m³/h Ø 80	9401
		RDR 30 m³/h Ø 80	9402
		RDR 45 m³/h Ø 80	9403
		RDR 50 m³/h Ø 80	9404
Ø 100 RDR 80 + 1 spacer	15 to 50 m³/h	RDR 15 m³/h Ø 100, 1 spacer	9405
		RDR 25 m³/h Ø 100, 1 spacer	9406
		RDR 30 m³/h Ø 100, 1 spacer	9407
		RDR 45 m³/h Ø 100, 1 spacer	9408
		RDR 50 m³/h Ø 100, 1 spacer	9409
Ø 100 RDR 100	50 à 100 m³/h	RDR 60 m³/h Ø 100	9410
		RDR 75 m³/h Ø 100	9411
		RDR 90 m³/h Ø 100	9412
		RDR 100 m³/h Ø 100	9413
Ø 125 RDR 80 + 1 double spacer	15 to 50 m³/h	RDR 15 m³/h Ø 125, 1 spacer	9415
		RDR 25 m³/h Ø 125, 1 spacer	9416
		RDR 30 m³/h Ø 125, 1 spacer	9417
		RDR 45 m³/h Ø 125, 1 spacer	9418
		RDR 50 m³/h Ø 125, 1 spacer	9419
Ø 125 RDR 100 + 1 spacer	50 to 100 m³/h	RDR 60 m³/h Ø 125, 1 spacer	9420
		RDR 75 m³/h Ø 125, 1 spacer	9421
		RDR 90 m³/h Ø 125, 1 spacer	9422
		RDR 100 m³/h Ø 125, 1 spacer	9423
Ø 125 RDR 125	100 to 180 m³/h	RDR 120 m³/h Ø 125	9425
		RDR 150 m³/h Ø 125	9426
		RDR 180 m³/h Ø 125	9427
Ø 150 RDR 80 + 2 spacers	15 to 50 m³/h	RDR 50 m³/h Ø 150, 2 spacers	9430
1 double spacer + 1 single spacer			
Ø 150 RDR 100 + 2 spacers	50 to 100 m³/h	RDR 100 m³/h Ø 150, 2 spacers	9431
Ø 150 RDR 125 + 1 spacer	100 to 180 m³/h	RDR 120 m³/h Ø 150, 1 spacer	9432
		RDR 150 m³/h Ø 150, 1 spacer	9433
		RDR 180 m³/h Ø 150, 1 spacer	9434
Ø 150 RDR 150	180 to 300 m³/h	RDR 210 m³/h Ø 150	9435
		RDR 240 m³/h Ø 150	9436
		RDR 250 m³/h Ø 150	9437
		RDR 270 m³/h Ø 150	9438
		RDR 300 m³/h Ø 150	9439

	Flow	Description	Code
Ø 160 RDR 80 + 2 spacers	15 to 50 m³/h	RDR 50 m³/h Ø 160, 2 spacers	9440
1 double spacer + 1 single spacer			
Ø 160 RDR 100 + 2 spacers	50 to 100 m³/h	RDR 100 m³/h Ø 160, 2 spacers	9441
Ø 160 RDR 125 + 1 spacer	100 to 180 m³/h	RDR 120 m³/h Ø 160, 1 spacer	9442
		RDR 150 m³/h Ø 160, 1 spacer	9443
		RDR 180 m³/h Ø 160, 1 spacer	9444
Ø 160 RDR 160	180 to 300 m³/h	RDR 210 m³/h Ø 160	9445
		RDR 240 m³/h Ø 160	9446
		RDR 250 m³/h Ø 160	9447
		RDR 270 m³/h Ø 160	9448
		RDR 300 m³/h Ø 160	9449
Ø 200 RDR 100 + 3 spacers	50 to 100 m³/h	RDR 100 m³/h Ø 200, 3 spacers	9456
Ø 200 RDR 125 + 2 spacers	100 to 180 m³/h	RDR 180 m³/h Ø 200, 2 spacers	9457
Ø 200 RDR 160 + 1 spacer	180 to 300 m³/h	RDR 210 m³/h Ø 200, 1 spacer	9460
		RDR 240 m³/h Ø 200, 1 spacer	9461
		RDR 250 m³/h Ø 200, 1 spacer	9462
		RDR 270 m³/h Ø 200, 1 spacer	9463
		RDR 300 m³/h Ø 200, 1 spacer	9464
Ø 200 RDR 200	300 to 500 m³/h	RDR 350 m³/h Ø 200	9465
		RDR 400 m³/h Ø 200	9466
		RDR 450 m³/h Ø 200	9467
		RDR 500 m³/h Ø 200	9468
Ø 250 RDR 125 + 3 spacers	100 to 180 m³/h	RDR 180 m³/h Ø 250 , 3 spacers	9476
Ø 250 RDR 160 + 2 spacers	180 to 300 m³/h	RDR 300 m³/h Ø 250 , 2 spacers	9477
Ø 250 RDR 200 + 1 spacer	300 to 500 m³/h	RDR 350 m³/h Ø 250, 1 spacer	9480
		RDR 400 m³/h Ø 250, 1 spacer	9481
		RDR 450 m³/h Ø 250, 1 spacer	9482
		RDR 500 m³/h Ø 250, 1 spacer	9483
Ø 250 RDR 250	450 to 800 m³/h	RDR 550 m³/h Ø 250	9485
		RDR 600 m³/h Ø 250	9486
		RDR 650 m³/h Ø 250	9487
		RDR 700 m³/h Ø 250	9488
		RDR 750 m³/h Ø 250	9489
		RDR 800 m³/h Ø 250	9490



anjos

01230 TORCIEU – Tél. : +33 (0)4 74 37 44 44

anjos.com